

Installationsanleitung

Klingeltaster VETRO mit individueller Gravur

1. Montage der Etagenplatte Mounting of the storey plate

Aufputz Adapter mit einer Wasserwaage am Mauerwerk ausrichten und mit dem mitgelieferten Befestigungsmaterial befestigen.

Align the surface-mounted adapter with the masonry using a spirit level and fasten it with the fastening material supplied.

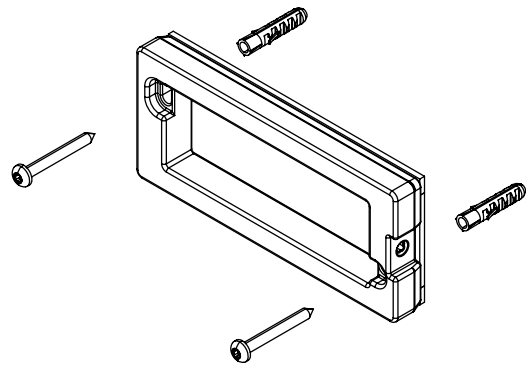
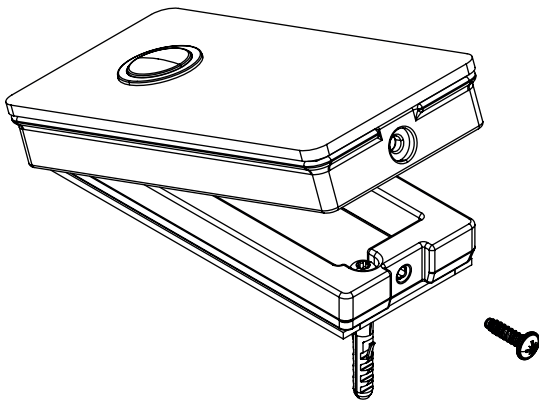

Elektrischen Anschluss herstellen, Etagenplatte an der Tasterseite über den Aufputz Adapter stülpen und zu klappen. Mit der mitgelieferten Schraube die Etagenplatte am Aufputz Adapter befestigen.

Make the electrical connection, put the shelf plate on the push-button side over the surface-mounted adapter and fold it closed. Fasten the shelf plate to the surface-mounted adapter with the screw supplied.

2. Anschluss des PROTACT-Tasters Connecting the PROTACT push button

